

AquaScat S

In-line turbidity measurement for the water treatment



Certificates and Conformities



ACS (Attestation Conformité Sanitaire)

DWI (Drinking Water Inspectorate)

Applications

- Monitoring of UV systems
- Monitoring of ultrafiltration systems
- Turbidity measurement in treated water
- Monitoring of reservoirs and water distribution networks
- Turbidity in process water

Characteristics

- Measurement of turbidity and temperature directly in the water
- Comparison with secondary turbidity standard
- Highly accurate measurements even in reflective pipes
- Extremely low maintenance
- Various installation options (process connections)
- Various options for displaying and transmission of measurement data to process control system/ SCADA

Industries

- Drinking water treatment
- Beverage and food industry
- Process water treatment in a wide range of industries

Innovations with true customer benefits



Outstanding measurement accuracy & stability

- Measurement accuracy of $\pm 1\%$ or ± 0.007 FNU – ideal for precise filtration monitoring and quality control
- The absorber has a light trap: stray light effects are minimised
- Precise measurements of a few mFNU are possible
- Very low drift: precise and comparable measurement values, even after months of operation

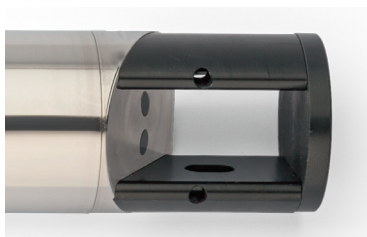

Minimal maintenance, maximum availability

- Slanted, self-cleaning sensor head: flow automatically cleans the optical surface automatically – no mechanical wiper required
- Factory 7-point calibration over the entire measuring range of the sensor (0 – 4000 FNU)
- A secondary turbidity standard (solids reference) is available for recalibration during operation. No toxic formazine required



Robust design & suitable for outdoor use

- Stainless steel (1.4571/316Ti), PPSU, sapphire glass – ideal for corrosion resistance and suitable for demanding environments
- No moving parts
- IP67 protection (standard sensor with M12 8-pin connector) / IP68 protection (immersion version with fixed cable)
- Display in total suspended solids possible (TSS)



Flexible system integration & connection options

The AquaScat S offers various options for integration into the process control system.

- Direct: via analogue or digital output (no control unit required)
- Sicon/Sicon M control unit for data visualisation and simple parameterisation of the sensor
- Conn-R connection box: For basic operation of the sensor

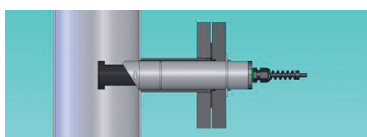

Flexible process connections

- Steel pipe with welded flange (DN40, DN50, DN80)
- With a fitting for PE or PVC pipes
- PVC bypass measuring cell
- Exchangeable fitting
- Immersed directly in the tank

Main technical details

Measuring principle:	90° scattered light according to standard ISO 7027/EN27027
Measuring range:	0 ... 4,000 FNU / ~0 ... 5,000 mg/L TSS*
Resolution:	0.001 FNU
Medium temperature:	0 °C ... +60 °C
Sample flow:	max. 3.0 m/s
Protection class:	IP67 (standard sensor) / IP68 (immersion version)
Accuracy:	0 – 50 FNU: ± 0.002 FNU or $\pm 1\%$ / 50 – 4000 FNU: $\pm 2\%^{**}$

* TSS value based on measurement with diatomaceous earth mg/L TSS ~ 1.3 x FNU. Calibration is substance-dependent.

** Based on factory standard.

Full details and technical data:



AquaScat S

Technical Data

Instrument data

Measuring principle:	90° scattered light according to standard ISO 7027/EN27027
Light source:	LED 860 nm
Measuring range:	0 ... 4,000 FNU ~ 0 ... 5,000 mg/L TSS*
Resolution:	0.001 FNU
Accuracy:	0 – 50 FNU: ± 0.002 FNU or ±1% / 50 – 4000 FNU: ± 2%**
Repeatability:	0.001 FNU or ± 0.1%
Medium temperature:	0 °C ... +60 °C
Temperature measurement:	0.1 °C
Pressure:	max. 10 bar @ 20 °C
Sample flow:	max. 3.0 m/s (inline) 0.2...2.0 l/min (bypass)
Pipe diameter:	min. 60 mm (inline installation)
Ambient humidity:	0–100%
Protection class:	IP67 (standard sensor) / IP68 (submersible version)
Power supply:	24 VDC +/-10%, galvanically isolated from housing
Power consumption:	max. 2 W
Materials used:	Stainless steel (316Ti/1.4571), PPSU, sapphire glass
Dimensions:	Ø 40 × 200 mm

Connection variants

Direct

1 × 0/4 ... 20 mA output (negative pole on GND of 24 V power supply)
2 × digital outputs (24 V, high-side, max. 25 mA)

Sicon/Sicon M control unit

8 × 4 ... 20 mA outputs
7 × digital outputs
5 × digital inputs
Modbus TCP
Modbus RTU
Profibus DP
Profinet IO

Conn-R connection box

1 × 4 ... 20 mA output (negative pole to GND of 24 V power supply)
2 × relay outputs 230 VAC 4A Button for adjustment
LED for status display

The submersible version must be connected via a controller.

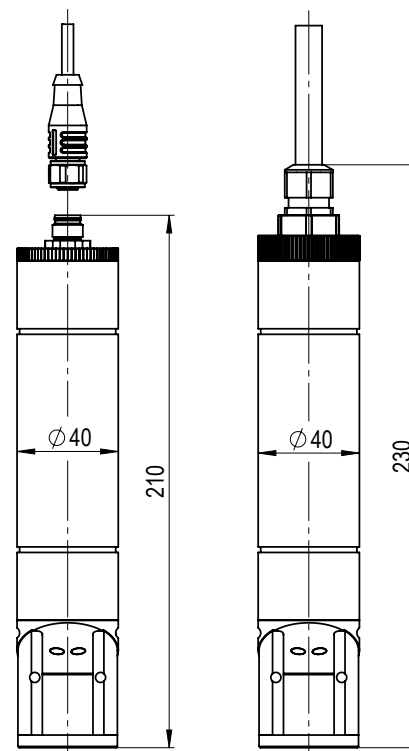

Standardversion
standard version

Eintauchversion
submersible version



* TSS value based on measurement with diatomaceous earth mg/L
TSS ~ 1.3 x FNU. Calibration is substance-dependent.

** Based on factory standard.